

**Pasta Magic**  
**17/8SMS/17/8BC/17/8C**  
Service and Parts



Frymaster, a member of the Commercial Food Equipment Service Association, recommends using CFESA Certified Technicians.

**24-Hour Service Hotline 1-800-551-8633**

**APR 2012**

**\* 8196896A \***

**NOTICE**

IF, DURING THE WARRANTY PERIOD, THE CUSTOMER USES A PART FOR THIS MANITOWOC EQUIPMENT OTHER THAN AN UNMODIFIED NEW OR RECYCLED PART PURCHASED DIRECTLY FROM FRYMASTER/DEAN, OR ANY OF ITS AUTHORIZED SERVICE CENTERS, AND/OR THE PART BEING USED IS MODIFIED FROM ITS ORIGINAL CONFIGURATION, THIS WARRANTY WILL BE VOID. FURTHER, FRYMASTER/DEAN AND ITS AFFILIATES WILL NOT BE LIABLE FOR ANY CLAIMS, DAMAGES OR EXPENSES INCURRED BY THE CUSTOMER WHICH ARISE DIRECTLY OR INDIRECTLY, IN WHOLE OR IN PART, DUE TO THE INSTALLATION OF ANY MODIFIED PART AND/OR PART RECEIVED FROM AN UNAUTHORIZED SERVICE CENTER.

** DANGER**

Improper installation, adjustment, alteration, service, or maintenance can cause property damage, injury, or death. Read the installation, operating, and service instructions thoroughly before installing or servicing this equipment.

** DANGER**

For your safety, do not store or use gasoline or other flammable liquids or vapors in the vicinity of this or any other appliance.

** DANGER**

This equipment is intended for indoor use only. Do not install or operate this equipment in outdoor areas.

** DANGER**

Do not operate this equipment unless it has been properly installed and checked by qualified personnel.

** DANGER**

Do not operate this equipment unless all covers and access panels are in place and properly secured.

** DANGER**

Do not attempt to repair or replace any component of this equipment unless power to the unit has been disconnected.

** DANGER**

If the power supply cord is damaged, it must be replaced by the manufacturer or its service agent or similarly qualified persons in order to avoid a hazard.

** DANGER**

Use caution when setting up, operating, or cleaning this equipment to avoid contact with heated surfaces.

** DANGER**

Do not use water jets to clean this equipment.

# ELECTRIC COOKER MODELS 17SMS, 17BC, 17C

## TABLE OF CONTENTS

---

### **CHAPTER 1: General Information**

1.1	Functional Description.....	1-1
1.2	Accessing Equipment.....	1-2
1.3	Replacing Components.....	1-2
1.4	Troubleshooting.....	1-11
1.4.6	Troubleshooting Guide.....	1-14

### **CHAPTER 2: Installation Instructions**

2.1	Accessories.....	2-1
2.2	Wiring Diagrams.....	2-11

# ELECTRIC COOKER MODELS 17/8SMS, 17/8BC, 17/8C

## CHAPTER 1: SERVICE PROCEDURES

---

### 1.1 Functional Description

The 17kW Pasta Magic Electric Cooker contains a 16.5-gallon (62.5-liter) stainless steel cookpot. The 8kW unit has a 8.75 gallon (33 liter) cookpot. The water in the cookpot is heated by a pair of heating elements. Electrical power to the elements is controlled by a solid-state SMS III *Spaghetti Magic* computer specifically modified for this application. **NOTE:** The SMS III computer used in the Pasta Magic is identical in appearance to the SMS III computers used in other model lines, but differs internally. The SMS is equipped with a basket lift, and also features automatic filling (AutoFill) and automatic skimming (AutoSkim). This model also has a swing-away jointed faucet. The SMS and BC models have an attached 16.5-gallon (84.1-liter) rinse tank.

Turn the Master Power Switch ON and press the computer Power switch. A logic circuit checks the water level by looking for a ground at the upper water-level sensor. A normally closed solenoid valve opens if no ground is seen, indicating water is below the sensor, and water enters the cookpot. The unit enters the Simmer mode when the heating elements are covered (indicated by grounding of the low-water sensor). The cookpot continues to fill until water reaches the upper water-level sensor and the solenoid closes. The cooker stays in Simmer mode until the Boil mode switch is pressed or the unit is turned off. The water solenoid valve opens when the water level is below the upper water-level sensor.

Logic circuits in the computer monitor the temperature and cycle power on and off to maintain the simmer setpoint. The cooker also has a high-limit safety. If the cookpot fails to refill and the water level drops below the low-water sensor, the high-limit will open, cutting off power to the elements, when the element temperature reaches  $400 \pm 15^{\circ}\text{F}$ .

Pressing the Skim switch activates the AutoSkim feature. A logic circuit in the computer opens the solenoid valve in the water supply line for three seconds every minute until the option is turned off by again pressing the Skim switch.

The operator enters a cooking time by pressing the number pads on the computer. The computer counts down the cook cycle time when the Start switch is pressed. When the computer times out, an alarm sounds briefly, then the timer reverts to the last time entered.

Logic circuits in the computer also activate the basket lift motors when the Start switch is pressed, lowering the basket into the cookpot. A pair of motors drives the basket lift arms down until a cam attached to the left motor loses contact with a roller-activated microswitch and power to the motors is cut. When the computer times out, the logic circuits reverse the switch positions so that the motor circuit is again completed and the motors are restarted, raising the basket from the cookpot. The cam again makes contact with the microswitch at the raised position, cutting power to the motors and stopping the lift in the up position.

## 1.2 Accessing Equipment for Servicing

### DANGER

**Moving this equipment while it is filled with hot water may cause spilling or splattering of the hot water. Always drain the cookpot before attempting to relocate this equipment for servicing.**

1. Disconnect the unit from the electrical power supply and from the water supply.
2. Remove any attached restraining devices.
3. Relocate the unit for service accessibility.
4. After servicing is complete, reconnect the unit to the water supply, reattach restraining devices, and reconnect the unit to the electrical power supply.

## 1.3 Replacing Equipment Components

### 1.3.1 Replacing the Computer

1. Disconnect the cooker from the electrical supply.
2. Remove the two screws in the upper corners of the control panel and swing the panel open from the top, allowing it to rest on its hinge tabs.
3. Disconnect the wiring harness from the back of the controller.
4. Disconnect the ground wire from the controller. Remove the controller by lifting it from the hinge slots in the frame.
5. Reverse the procedure to install a new controller.



Computer wiring harness.

### 1.3.2 Replacing Fuses

1. The 15-amp fuses are located in holders mounted on front of the box.
2. Remove the cover and replace the fuse.

### 1.3.3 Replacing Electronic Components Other than the Computer

1. Drain the cookpot and disconnect the cooker from the electrical power supply.
2. Remove the covers from the component box.
3. On the component to be replaced, make a note of the wiring connection points.
4. Disconnect the wires and remove the failed component. Install the replacement component and reconnect the wiring in accordance with the notes made in Step 3 or with the wiring diagram on the door of the unit.
5. Replace the component box covers, being sure to reconnect the ground wire. Reconnect the cooker to the electrical power supply.

### 1.3.4 Replacing a Heating Element

1. Drain the cookpot and disconnect the cooker from the electrical power supply. Disconnect the unit from the water supply at the rear of the cooker. Remove the basket lift arms from the unit.
2. Reposition the cooker to allow clear access to the rear of the unit. Remove the upper and lower basket lift panels.
3. Unplug the element connector from the rear of the component box. Depress the locking tabs on each side of the connector and extend the connector to release the element leads (see photo at right). Pull each of the leads out of the connector, being careful not to damage the connector in the process.
4. If the bundle of element leads is enclosed in a fiberglass insulating sheath, cut the wire ties securing the sheath in place, and remove and discard it; it is no longer required. If replacing the left element (as viewed from the front of the cooker), cut the metal wire ties that secure the high-limit thermostat to the element, being careful not to bend the thermostat in the process.

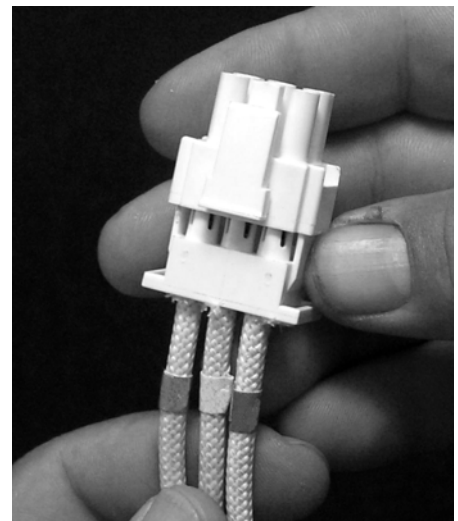

5. Remove the brass nuts that secure the element in the cookpot and lift the failed element from the cookpot. Recover the Teflon washers from the failed element for use on the replacement.

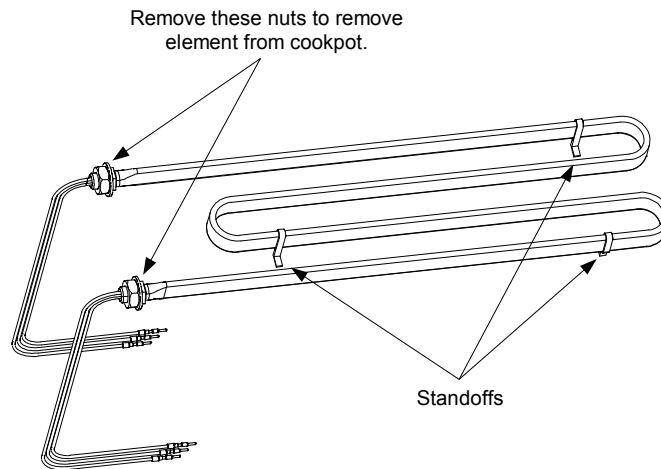

6. Position the replacement element in the cookpot with the standoffs on the bottom of the cookpot. Thread the element leads through the Teflon washers recovered from the failed element. Secure the element in place with the nuts removed in Step 5.
7. If the left element (as viewed from the front of the cooker) was replaced, secure the high-limit thermostat against the inside of the leg of the element with two metal wire ties.
8. Insert the pins on the element leads into the element connector in accordance with the illustration below. The insulation on the lead will be flush with the face of the plug when properly positioned. When all leads are positioned correctly, close the connector and verify that the tabs are locked in place. Each element lead is marked with a number that corresponds to the hole in the connector into which it should be inserted. The right element (as viewed from the rear of the unit) uses the 6-pin connector; the left element uses holes 1 through 6 of the 9-pin connector.

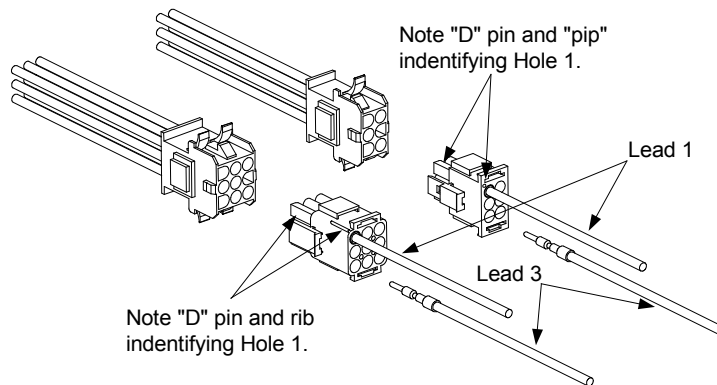

9. Bundle all six element leads together and secure with plastic wire ties close to the element and connector, and in the middle.
10. Reverse Steps 1 through 3 to complete the procedure.

### 1.3.5 Replacing the High-Limit Thermostat

1. Drain the cookpot and disconnect the cooker from the electrical power supply. Disconnect the unit from the water supply at the rear of the cooker. Remove the basket lift arms from the unit and cut the metal wire ties securing the thermostat tube to the element.

2. Reposition the cooker to allow clear access to the rear of the unit. Remove the upper and lower basket lift panels.
3. At the rear of the cookpot, loosen the small compression nut, and then unscrew the large fitting from the cookpot. Pull the thermostat tube out through the rear of the cookpot.

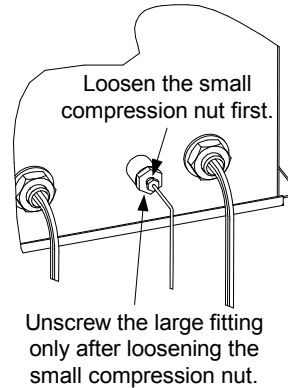

4. Detach the high-limit thermostat leads (5C and 8C) from the thermostat. Remove the two screws securing the thermostat to the mounting bracket and remove the thermostat assembly from the cabinet. (**NOTE:** It is not necessary to remove the bracket.)
5. Loosen the small compression nut in the large fitting on the replacement thermostat so that the large fitting will move freely on the capillary tube (the thin, flexible tube). Carefully insert the replacement thermostat into the cookpot, being careful not to bend the thermostat tube. Position the tube along the inside of the left leg of the element (as viewed from the front of the cooker) and secure it in place with two metal wire ties. Apply thread sealer to the large fitting and screw the fitting securely into the cookpot. When the large fitting is tight, pull gently on the capillary tube to remove any slack, then screw the small compression nut into the large fitting and tighten.
6. Coil the capillary tube as necessary to achieve a neat installation and attach the terminal block to the mounting bracket using the screws removed in Step 4. Connect thermostat lead 5C (black) to the normally closed (NC) terminal and 8C (white) to the common (C) terminal.

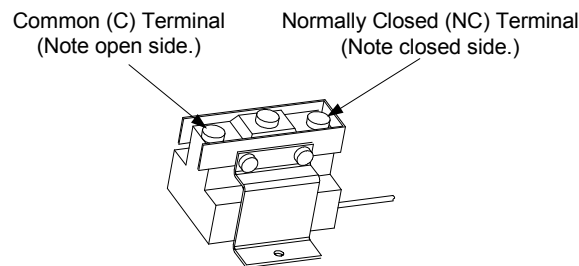

7. Reverse Steps 1 and 2 to complete the procedure.

### 1.3.6 Replacing a Water-Level Sensor in 17kW Unit

Drain the cookpot and disconnect the cooker from the electrical power supply. Disconnect the sensor lead from the sensor, remove the nuts securing the sensor in place, and remove the sensor. Install the replacement sensor as illustrated below and reconnect the lead.

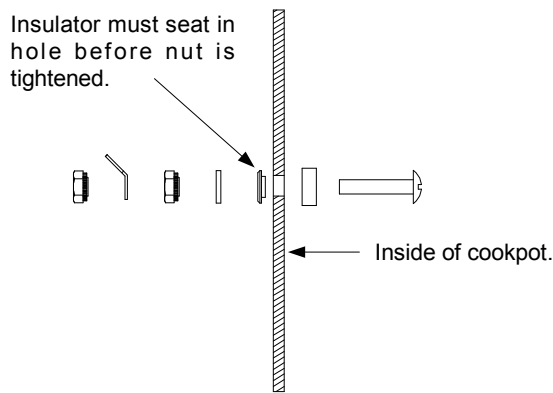

### 1.3.7 Replacing the Temperature Probe

1. Drain the cookpot and disconnect the cooker from the electrical power supply.
2. Remove the three screws along the upper edge of the control panel and open the panel by allowing it to swing downward.
3. Disconnect the 15-pin connector from the rear of the computer and, using a pin pusher (such as Frymaster P/N 806-4855), push out the temperature probe (red and white) leads from positions 13 and 14 on the connector.
4. Remove the temperature probe by unscrewing it from the front of the cookpot.
5. Apply thread sealer to the replacement probe and screw it securely into the cookpot.
6. Insert the red probe lead into position 13 of the 15-pin connector and the white lead into position 14. Pull gently on each lead to ensure it is firmly seated.

#### Testing Probe Resistance

A properly operating probe should produce these resistances at these temperatures:

- 552  $\Omega$  @ 60°F (16°C)
- 665  $\Omega$  @ 100°F (38°C)
- 1000  $\Omega$  @ 212°F (100°C)

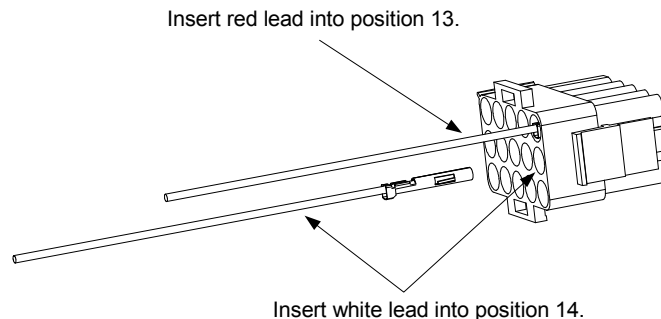

7. Reattach the 15-pin connector to the rear of the computer, close the control panel, and replace the three screws removed in Step 2.

### 1.3.8 Replacing a Water Level Sensor or the Temperature Probe in 8 kW Unit

1. Drain the cookpot and disconnect the cooker from the electrical power supply.
2. Remove the basket lift arm by lifting it straight up from the lifter rod. Remove the probe cover by lifting it straight up from the probe block.

- At the rear of the unit, remove the two screws securing the access panel and remove the panel.

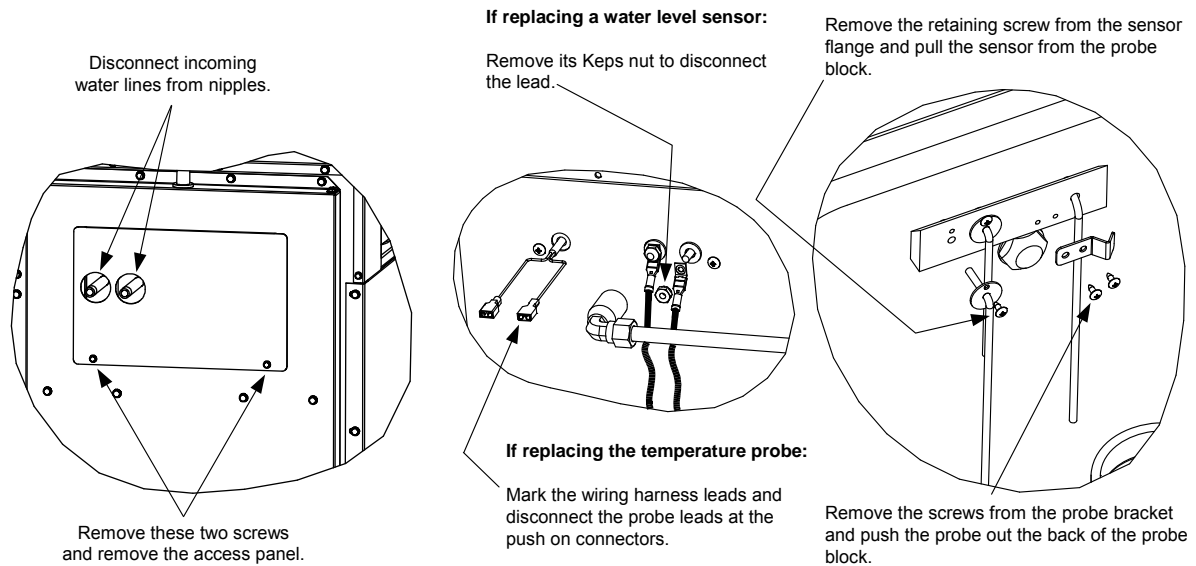

- If replacing a water level sensor:

- Disconnect the lead by removing the keps nut holding it in place.
- Remove the screw in the sensor flange.
- Carefully pull the failed sensor from the probe block and replace with the new sensor.
- Reattach the lead and reverse Steps 1-3 to complete the procedure.

- If replacing the probe:

- Mark the wiring harness leads and disconnect them from the probe leads at the push-on connectors.
- Remove the two screws in the probe bracket.
- Carefully pull the probe from the probe block and replace with the new probe.
- Reattach the leads and reverse Steps 1-3 to complete the procedure.

### 1.3.9 Replacing the Pressure Regulator or Solenoid Valve

- Drain the cookpot and disconnect the cooker from the electrical power supply. Turn off or disconnect the water supply to the cooker.
- Loosen the compression fittings on the water lines running to and from the regulator and remove the regulator from the unit. (**NOTE:** If the cooker is equipped with the optional Autofill feature, the solenoid valve is installed between the regulator and the cookpot. If that is the case, disconnect the solenoid leads and remove both the regulator and solenoid valve from the unit.)

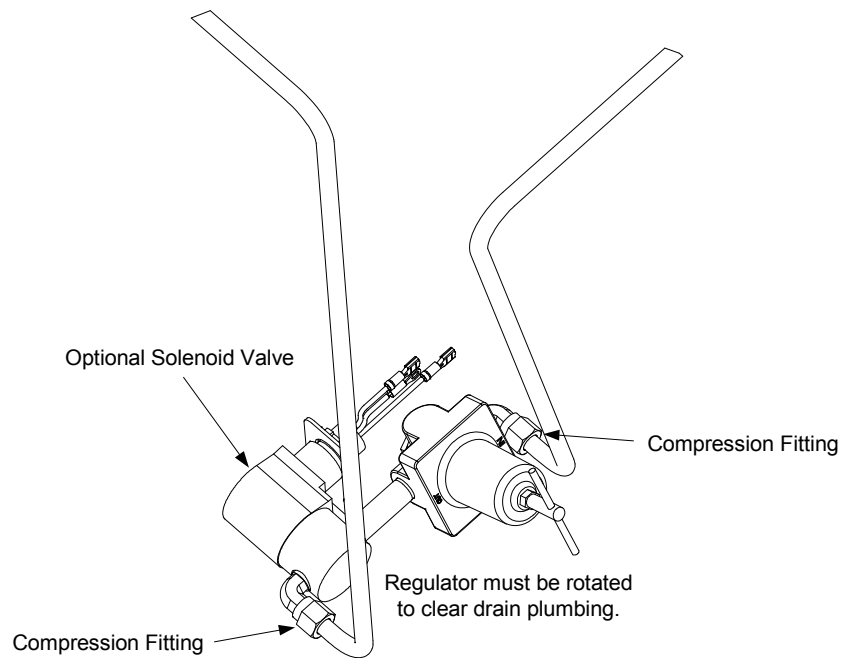

3. If replacing the regulator, adjust the replacement regulator output pressure to not more than 40 PSI (28.15 kg/cm<sup>2</sup>) before installation in the cooker.
4. Recover the fittings from the failed component (regulator or solenoid valve) and install them on the replacement, using thread sealer on all connections.
5. Reverse Steps 1 and 2 to complete the procedure, being sure to apply thread sealer to all connections. **NOTE:** The regulator must be rotated approximately 45 degrees to clear the drain plumbing (see illustration at Step 2).

### 1.3.10 Replacing the Water Faucet

1. Drain the cookpot and disconnect the cooker from the electrical power supply.
2. Turn off the water supply to the cooker and disconnect the incoming water lines where they attach to the stubs at the rear of the cooker.
3. Remove the two screws securing the access panel in place and remove the panel.
4. Disconnect the water supply line at the compression fitting where it attaches to the water inlet manifold. Remove the screws from the faucet mounting plate and lift the faucet assembly from the unit.

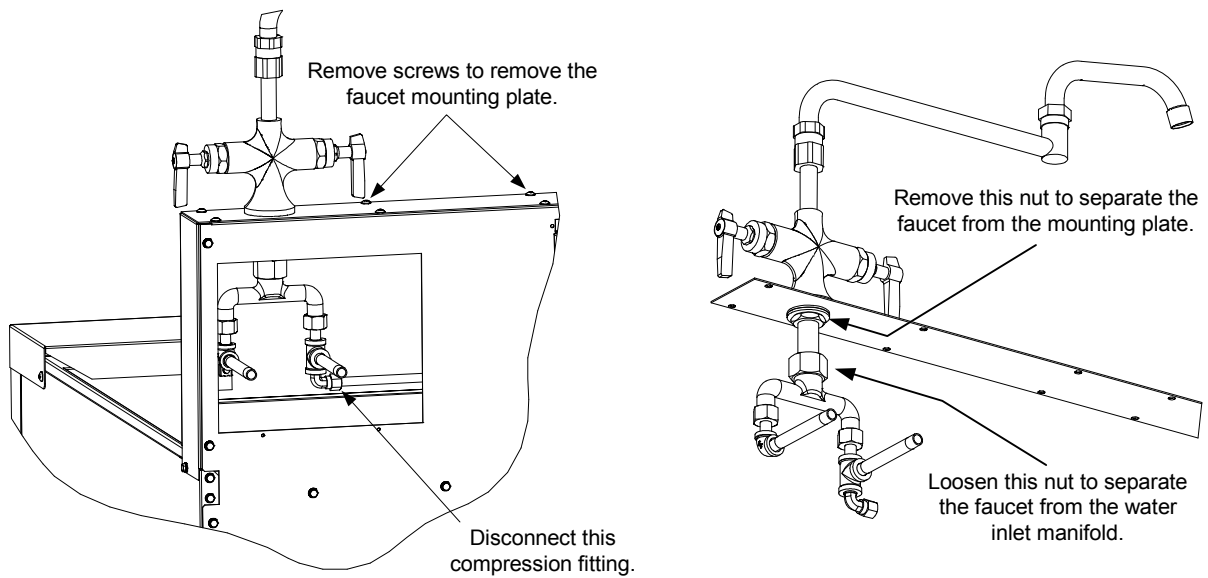

5. Separate the faucet from the water inlet manifold and mounting plate as shown in the illustration at Step 4.
6. Reverse Steps 1-5 to complete the procedure.

### 1.3.11 Replacing a Basket Lift Motor or Microswitch

1. Disconnect the cooker from the electrical power supply.
2. If rigid water connections have been used, disconnect the cooker from the incoming water supply.
3. Remove the basket lift arms from the lifter rods and then reposition the cooker to gain access to the rear. Remove the upper and lower basket lift rear panels.
4. Unplug the basket lift wiring harness from the lower 6-pin connector on the component box. (To do this, you must reach around behind the component box from the front of the cooker.)

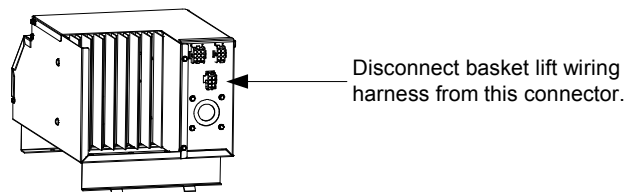

5. Disconnect the basket lift link from the lifter cam (bell crank) assemblies one at a time. When the link is disconnected from a cam, slip the corresponding lifter rod down and out of the assembly (see illustration).

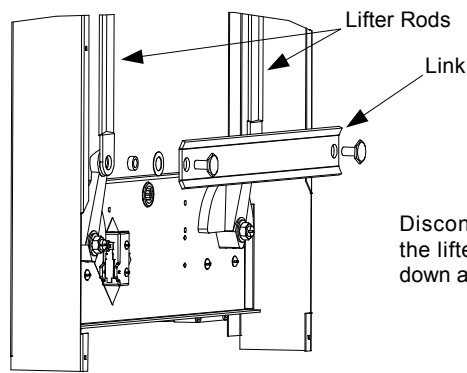

Disconnect the basket lift link from the lifter cams and slip the lifter rods down and out of the assembly.

6. Remove the four bolts securing the motor mount to the frame, then remove the motor and mount assembly from the unit. **NOTE:** It is possible to replace a motor or the microswitch without removing the motor and mount assembly, but it is much more difficult.
7. Dismount the motor or microswitch as shown below and install the replacement.

**NOTE:** The right motor dismounts in the same way as the left.

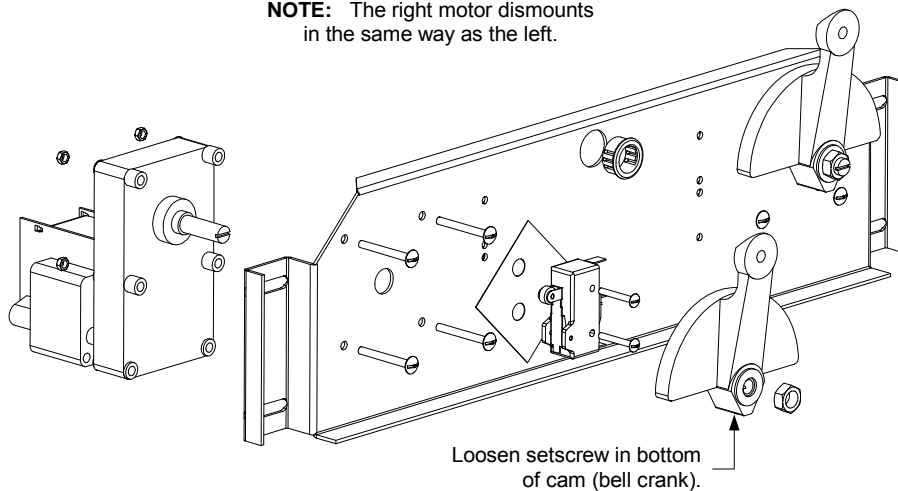

8. Reverse Steps 1-7 to complete the procedure.

### 1.3.12 Replacing the Cookpot or Rinse Tank

1. Remove the faucet assembly from the cooker in accordance with Steps 1-4 of Section 1.3.8.
2. Remove the screws that secure each of the rear corners of the backsplash assembly (see illustration at right). **NOTE:** To access the screw in the lower right corner (as viewed from the rear) remove the upper basket lift panel.

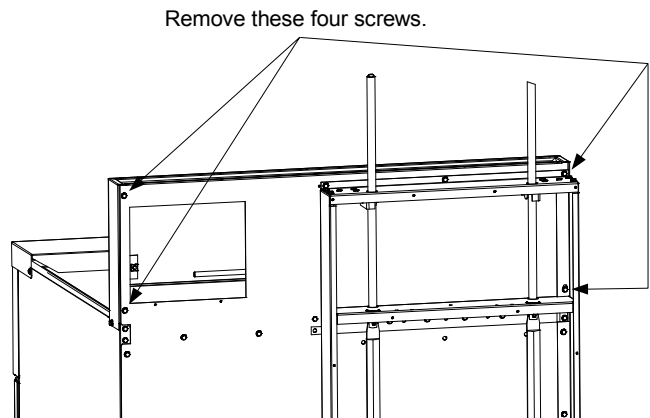

3. Remove the screws along the top edge of the control panel and open the panel by swinging it downward. Disconnect the connector from the rear of the computer, and then lift the control panel out of the control panel frame.

4. Remove the screws that secure the backsplash sides to the cabinet sides then remove the four screws that secure the topcap to the cabinet. Remove the nut and washer securing the basket support rod to the topcap by reaching up through the control panel frame. Conversely, the backsplash and topcap, with the basket support rod still attached, can be lifted up and off the cooker as one unit.

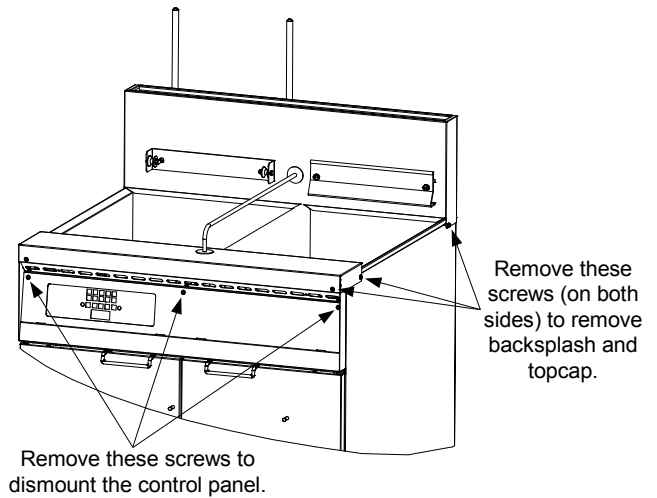

5. Remove the screws attaching the standoff brackets to the cookpot or rinse tank.

6. If removing the cookpot, unplug the element wiring harnesses from the rear of the contactor box. Disconnect the high-limit thermostat leads and the water-level sensor leads. Using a pin-pusher (such as Frymaster P/N 806-4855), disconnect the temperature probe leads from the 15-pin connector.

Remove these screws to release the pots from the standoff brackets.

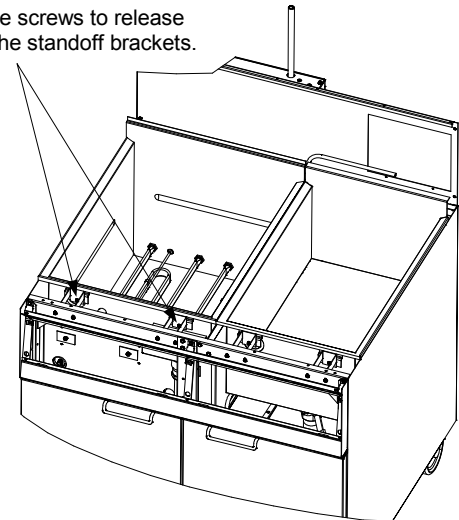

7. Disconnect the union joining the cookpot and rinse tank drain piping together.

8. With an assistant, lift the cookpot or rinse tank straight up and out of the cabinet.

9. Invert the cookpot or rinse tank on a suitable work surface and remove the salvageable components (e.g., elements, thermostats, drain plumbing, etc.). Install the recovered components on the replacement cookpot or rinse tank, using thread sealer on all connections.

10. Reverse Steps 1 through 8 to complete the procedure.

## 1.4 Troubleshooting

**NOTE:** The 24VAC power to the electronic components of this system is controlled by the master ON/OFF switch located on the front of the contactor box. If this switch is in the OFF position, none of the system components will function.

### DANGER

**The master ON/OFF switch does not disconnect this equipment from the electrical power source!** Line voltage is supplied to the transformer and to the basket lift motors as long as the unit is plugged in.

Problems with this equipment may be grouped into five broad categories:

1. Failure or malfunction of a 24VAC power-supply system component.
2. Failure or malfunction of the computer.
3. Failure or malfunction of an Autofill/AutoSkim system component.
4. Failure or malfunction of a water heating system component.
5. Failure or malfunction of a basket lift system component.

Sections 1.4.1 through 1.4.5 briefly explain the functioning of each of the systems mentioned above. Section 1.4.6 contains troubleshooting guides that provide systematic procedures to isolate and identify the specific source of a problem. A wiring diagram is located at the end of the chapter.

### 1.4.1 How the Power-Supply System Works

Line voltage is supplied to the system via a power cord that is plugged or hard-wired into the store's electrical service. The power cord is attached to a three-lug delta-power terminal block. One set of wires delivers line voltage from the load side of the block to Terminal 1 of each of the solid-state relays. A second set of wires delivers line voltage through a pair of fuses to the 24VAC transformer and to the basket lift relay. Line voltage for one side of the basket lift motor circuit is tapped from a "piggy-back" terminal on the line side of the transformer. Line voltage for the other side of the circuit is supplied via the basket lift relay. 24VAC is supplied to the equipment by placing the master ON/OFF switch in the ON position, which grounds the transformer.

### 1.4.2 How the Computer Works

The SMS III computer provides the interface between the operator and the system components. The computer is powered by 24VAC supplied through Pins 1 (hot) and 2 (ground) of the 15-pin wiring harness. Internal circuitry senses the water level, water temperature, and element temperature. Depending upon the conditions sensed, the computer energizes or de-energizes the solenoid valve to control water level and the heating elements to control water temperature. The computer also controls the lowering and raising of the basket lift, and activates an audible alarm, indicating a cooking cycle is complete. A rectifier in the computer converts 24VAC to the 24VDC required by the basket lift relay and the solid-state heating relays. The computer signals for heat via Pin 4, grounds the solenoid valve via Pin 6, and senses water level via pins 7 (low) and 9 (full). The temperature probe connects to Pins 13 and 14. The basket lift relay connects to pins 10 and 12. The sound device connects to pin 11.

### 1.4.3 How the Autofill/AutoSkim System Works

The heart of the automatic filling (Autofill) system is a normally closed solenoid valve that opens when 24VAC is applied.

The ground for the solenoid is supplied (via pin 6 of the computer wiring harness) so long as the upper water-level sensor is not in contact with the water in the cookpot. When the water in the cookpot reaches the upper water-level sensor, the sensor is grounded. This causes the computer to break the solenoid ground, closing the valve. Starch or lime build-up on the upper water-level sensor may keep a ground from forming, therefore always make sure the sensor is clean and its lead (pin 9 of the computer wiring harness) is firmly connected. Also, in order for the ground to form, there must be some mineral content in the water (pure water is non-conductive). Consequently, the units will not operate with distilled water. If distilled, highly filtered, or purified water is used, add 1/8-cup of baking soda to the water each time the cookpot is emptied and refilled.

When the AutoSkim feature is activated by pressing the skim switch on the computer, a logic circuit in the computer automatically opens the solenoid valve for three seconds every minute until the switch is again pressed. If the Autofill feature is working properly, failure of the AutoSkim feature will be due to a malfunctioning computer and not the solenoid valve. (Proper operation of the Autofill feature can be determined by draining water from the cookpot until the water level is below the upper water-level sensor. If the solenoid valve opens and then closes when the water in the cookpot again reaches the upper water-level sensor, the Autofill feature is working properly.)

### 1.4.4 How the Water Heating System Works

To prevent energizing the heating elements when there is no water in the cookpot, these units are equipped with a **low-water-level sensor**. This sensor must be grounded by contact with water in the cookpot before the control circuitry will apply power to the elements. Starch or lime build-up on the low-water-level sensor may keep the ground from forming, therefore always make sure the sensor is clean and its lead (pin 7 of the computer wiring harness) is firmly connected. In order for the ground to form, there must be some mineral content in the water (pure water is non-conductive). Consequently, the units will not operate with distilled water. If distilled, highly filtered, or purified water is used, add 1/8-cup of baking soda to the water each time the cookpot is emptied and refilled.

In addition to the low-water-level sensor discussed above, the water heating system has six more parts: the high-limit thermostat, the temperature probe, the contactor, the element, a group of three solid-state relays, and the computer.

The **high-limit thermostat** functions as a normally closed switch. If the water in the cookpot falls below the low-water-level sensor but the sensor remains grounded (for whatever reason), the high-limit switch will open when the element temperature reaches 400°F ±15 (204°C ± 9). This cuts power to the contactor coil and thus to the element.

The **temperature probe** is used only when the unit is in the simmer mode. When the operator selects the simmer mode, logic circuits in the computer monitor the temperature of the water and cycle power to the element to maintain the the programmed temperature.

The **contactor** is the terminal block to which the element leads are connected and where contact is made between the leads and the line voltage. Built into the contactor is a 24VAC coil that energizes

when the master ON/OFF switch is placed in the ON position. When it energizes, contact is made between the incoming line voltage and the element leads, and line voltage is supplied to one side of the element circuit. The **solid-state relays** control the supply of line voltage to the other side of the element circuit. The relays are closed when the computer is calling for heat and open when it is not.

The **element** is a resistive heating device. That is, when voltage is applied to the element, the element gets very hot due to its resistance to current flow through it. The heat generated is transferred directly to the water.

The **computer** is the interface between the operator and the other components of the equipment. In the water heating system, its function is to control the application of line voltage to the heating element via the solid-state relays.

When in the *Simmer Mode*, the signal from the computer is continuous, the solid-state relays are continuously closed, and line voltage is applied to the elements until the simmer setpoint (195°F/90.6°C) is reached.

When in the *Boil Mode*, the signal from the computer is continuous for approximately the first 40 seconds, then changes to a series of on-off pulses of equal duration. The solid-state relays close and open in response to the signal from the computer, and line voltage is applied to the elements accordingly. (The pulsing of the line voltage to the elements prevents the water in the cookpot from reaching a vigorous, roiling boil. This, in turn, minimizes the formation of starch foam. An added benefit of the pulsing is reduced electrical power consumption.)

#### **1.4.5 How the Basket Lift System Works**

When the Start switch is pressed to start the cooking cycle, logic circuits in the computer activate the basket lift motors, lowering the basket into the cookpot. As the motors drive the basket lift arms down, a cam attached to the left motor eventually loses contact with a roller-activated microswitch and power to the motors is cut. When the computer times out, logic circuits reverse the switch positions so that the motor circuit is again completed and the motors are restarted, raising the basket from the cookpot. At the fully raised position, the cam again makes contact with the microswitch, cutting power to the motors and stopping the lift in the up position.

## 1.4.6 Technician Troubleshooting Guides

Symptom	Potential Cause	Diagnosis
Computer doesn't activate	<ul style="list-style-type: none"> <li>• Master switch not on</li> <li>• Unit not plugged in.</li> <li>• Failed 24-volt transformer.</li> <li>• Failed or loose wiring.</li> </ul>	<ul style="list-style-type: none"> <li>• Turn switch on.</li> <li>• Plug unit in.</li> <li>• Test input and output voltage from transformer.</li> <li>• Check fuses in transformer circuit; check continuity of power switch in on position; check for 24VAC on pins 1 and 2 of the computer wiring harness.</li> </ul>
Cook pot fails to fill	<ul style="list-style-type: none"> <li>• Unit not connected to water supply.</li> <li>• Dirty or failed water sensor.</li> <li>• Failed water solenoid.</li> <li>• Failed controller.</li> </ul>	<ul style="list-style-type: none"> <li>• Connect to water supply.</li> <li>• Clean water sensors; add baking soda to cookpot water.</li> <li>• Check for 24VAC in water solenoid circuit.</li> </ul>
Unit fails to heat	<ul style="list-style-type: none"> <li>• Unit is not plugged in or breaker is open.</li> <li>• Hi-limit is open.</li> <li>• Probe resistance is out of tolerance.</li> <li>• Solid state relay failure.</li> <li>• Element failure.</li> </ul>	<ul style="list-style-type: none"> <li>• Plug unit in; check breaker.</li> <li>• Check continuity of hi-limit. Replace if open.</li> <li>• Check probe resistance at pins 13 and 14 of the 15-pin computer plug. See Testing Probe on page 1-6.</li> <li>• Check probe resistance between each pin and ground. Should be 2 mega Ohms or greater.</li> <li>• With the computer calling for heat, check for input voltage (5-10VDC) on the solid state relays and line voltage on the output terminals. Zero input voltage suggests a failed relay.</li> <li>• With the computer not calling for heat, check for input voltage (5-10VDC) and line voltage on the output terminal. No line voltage suggests a failed relay.</li> <li>• Ohm out element on pins 1- 6; 2-5; and 3-4. Resistance should be 15 Ohms <math>\pm</math>3.</li> </ul>

Symptom	Potential Cause	Diagnosis
Basket lift fails to work	<ul style="list-style-type: none"> <li>• Failed fuse</li> <li>• Failed computer.</li> <li>• Failed or loose wiring.</li> <li>• Failed basket lift relay.</li> <li>• Failed motor.</li> </ul>	<ul style="list-style-type: none"> <li>• Replace 15-amp fuse</li> <li>• With basket lift up, check for 27-33VDC at pin 10 of 15-pin plug. Zero volts if basket lift is down. No voltage: computer has failed.</li> <li>• With basket lift up, check for 27-33VDC (Zero voltage if basket lift is down) at basket lift relay terminal. None or improper voltage: check for loose or corroded wiring.</li> <li>• With basket lift up, is line voltage present at the NC (lower) terminal of basket lift microswitch (middle terminal with basket lift down)? This suggests a bad relay.</li> <li>• With basket lift up, is line voltage present at the common position of the microswitch. This suggests a failed motor.</li> </ul>

## 2.1 Parts List

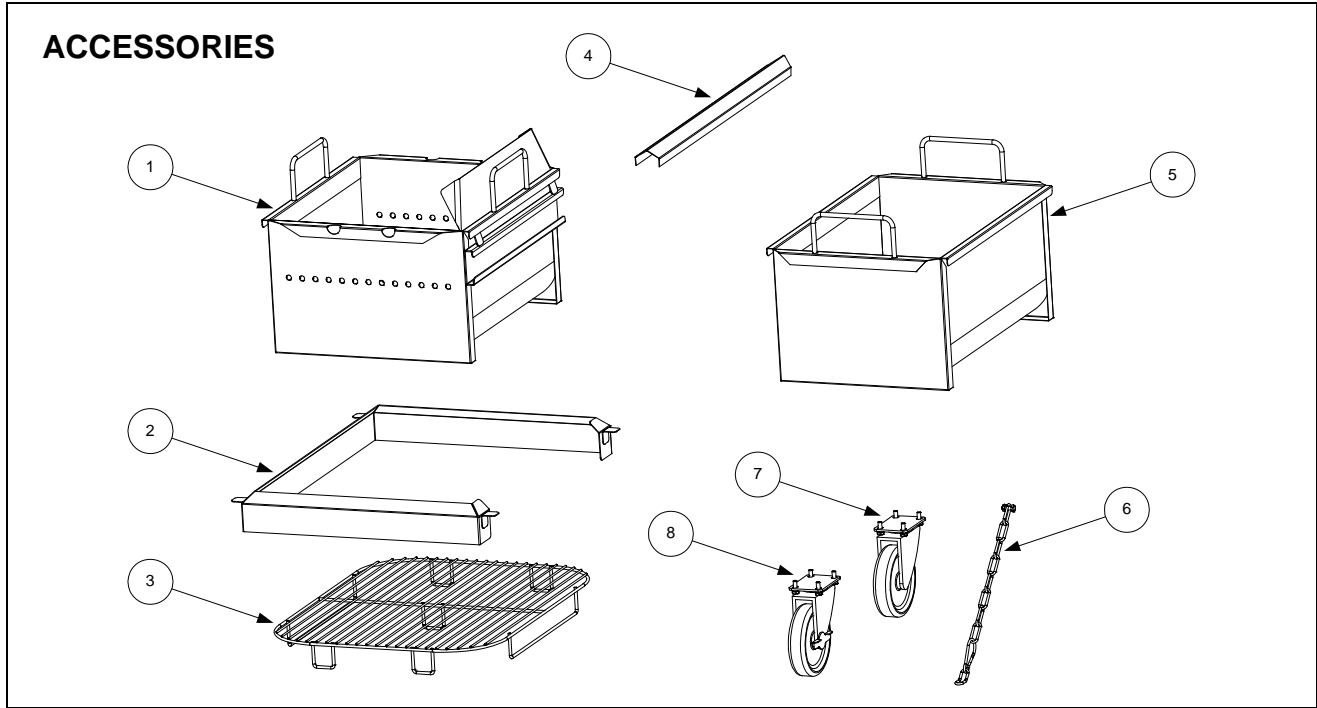

ITEM	PART #	COMPONENT
1	823-1910	Cooking Basket
*	823-7384	Basket, bulk
*	823-6290	Basket, wash
2	823-2936	Starch Diverter
*	803-0200	Rack, 12 portion
*	803-0238	Basket, round 5.5 x 8.5
*	803-0018	Cup, pasta portion (beige)
3	803-0332	Basket Support Rack
*	210-5068	Pan Insert
4	910-7540	Cookpot/Rinse Tank Top Connecting Strip
5	823-2938	Rinse Basket
6	826-0900	Chain Restraint Kit
7	826-1117	Caster without Brake, 5-Inch (includes mounting hardware)
8	826-1118	Caster with Brake, 5-Inch (includes mounting hardware)

# BASKET LIFT COMPONENTS

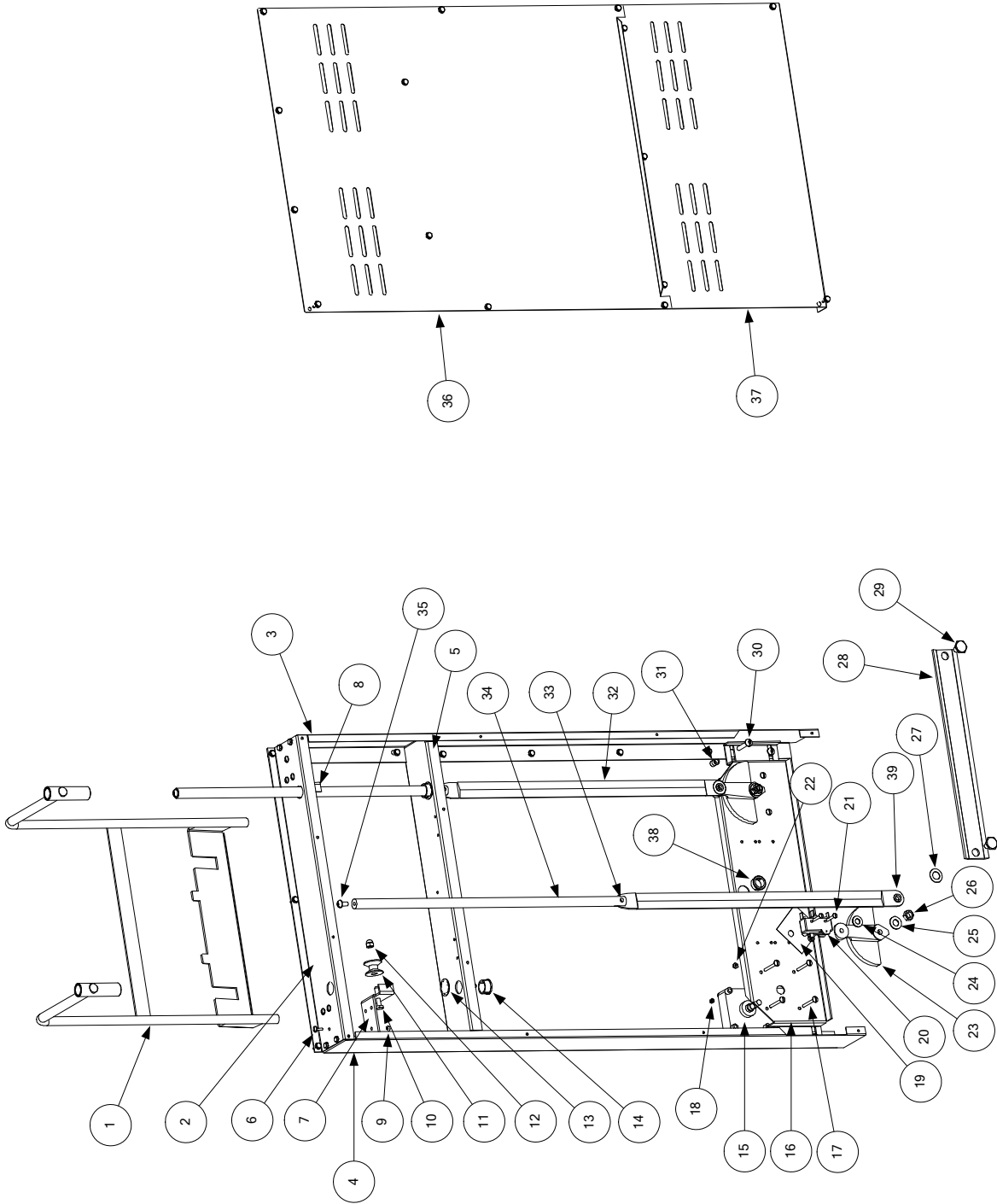

<b>ITEM</b>	<b>PART #</b>	<b>COMPONENT</b>
1	823-7061	Arms, Basket Lift, 17SMS
	823-7604	Arms, Basket Lift, 8SMS
2	910-7420	Top, Basket Lift Enclosure, 17 SMS
	910-1641	Top, Basket Lift Enclosure, 8SMS
3	222-3763	Side, Basket Lift Enclosure Right
4	221-3763	Side, Basket Lift Enclosure Left
5	900-7421	Support, Basket Lift Rod Bushing
6	826-1363	Screw, 8-32 x ½-inch Slotted Truss Head (Pkg of 25)
7	902-1927	Bracket, Left Basket Lift Roller
8	901-1927	Bracket, Right Basket Lift Roller
9	809-0247	Nut, 8-32 Hex Keps
10	809-0508	Bolt, ¼ -20 x 1 ¼-inch Hex Head SS
11	810-0194	Roller, Basket Lift
12	809-0047	Nut, ¼-20 SS Hex Cap
13	809-0082	Ring, ¾-inch Truarc
14	810-0045	Bushing, Basket Lift Rod
15	807-0108	Motor, 240VAC Basket Lift
16	900-7416	Mount, Basket Lift Motor
17	809-0113	Screw, 8-32 x 1 ½-inch Slotted Truss Head
18	809-0050	Nut, 8-32 Hex
19	812-0138	Insulation, Motor Mount (Fishpaper)
20	807-0240	Microswitch
21	809-0097	Screw, 6-32 x 1-inch Slotted Truss Head
22	826-1358	Nut, 6-32 Hex (Pkg of 25)
23	810-0052	Cam (Bellcrank), Basket Lift
24	809-0194	Washer, 5/16-inch SAE Flat
25	809-0196	Washer, ⅜-inch SAE Flat
26	809-0063	Nut, Jam 3/8-16 Hex
27	826-1381	Washer, ½-inch ID x ⅞-inch OD Nylatron Flat (Pkg of 10)
28	910-4525	Bar (Link), Basket Lift Synchronizing
29	809-0155	Screw, 5/16-18 x ⅝-inch Leveling
30	826-1370	Screw, ¼-20 x 1 ¼-inch Slotted Round Head (Pkg of 10)
31	809-0076	Nut, ¼-20 x ¾-inch Expansion
32	920-6076	Link, Basket Lift
33	810-0170	Pin, ¼-inch x ⅝-inch Spring Dowel
34	810-0192	Rod, 19 ⅝-inch Basket Lift
35	809-0127	Screw, ¼-20 x ½-inch Slotted Round Head
36	900-7418	Panel, Upper Basket Lift Rear
37	220-3761	Panel, Lower Basket Lift Rear
38	807-0124	Bushing, Heyco
39	810-0220	Spacer, Tubular, .493-inch OD

# 17 SMS CABINETY

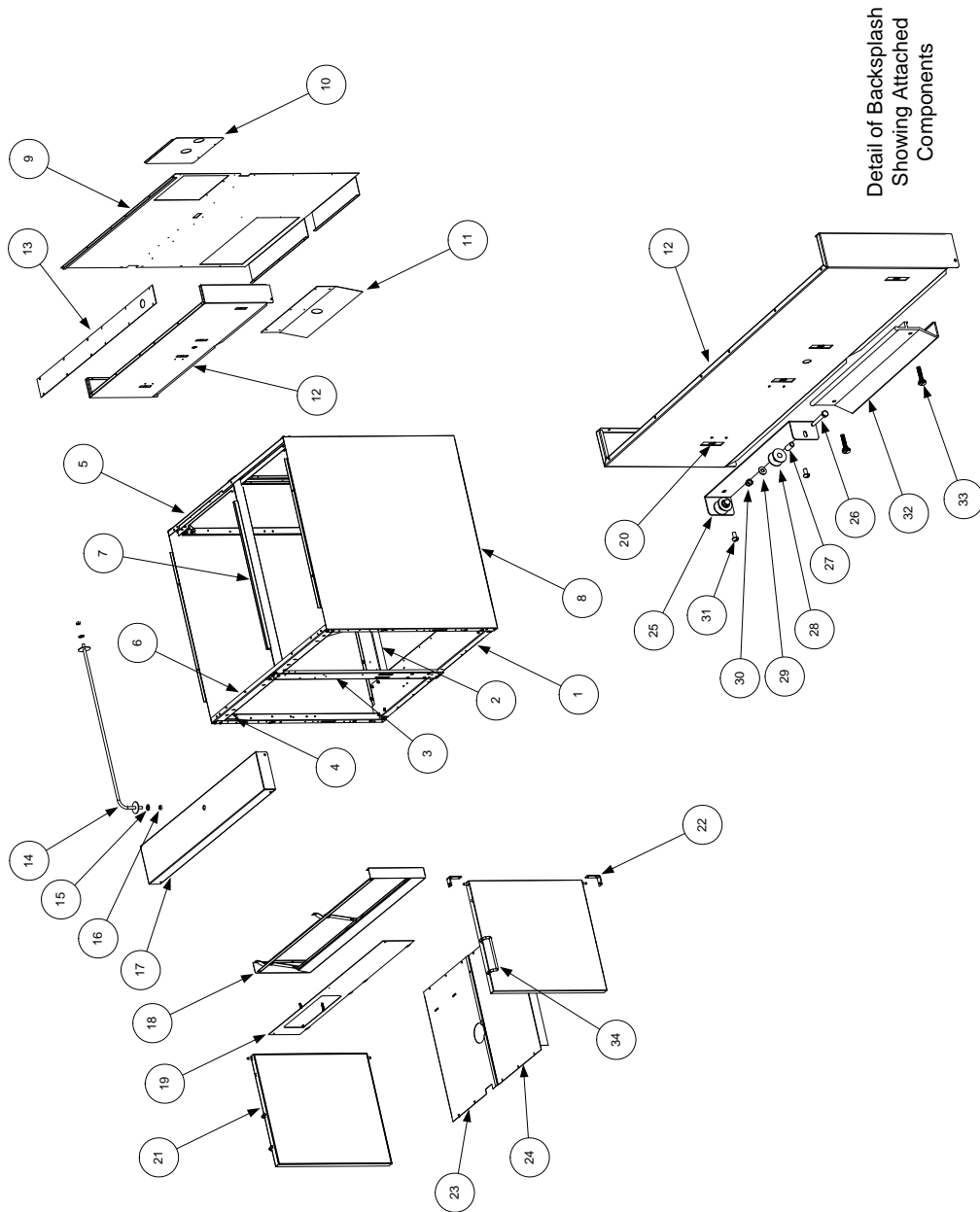

ITEM	PART #	COMPONENT
1	210-0815	Channel, Front or Rear Base
*	806-5209	Leg Pad Assembly (on bottom of Item 1, for mounting casters)
2	210-0816	Channel, Side Base
3	900-7198	Post, Door
4	900-1552	Gusset (Corner Brace)
5	900-7389	Brace, Top Rear
6	900-7390	Brace, Top Front
7	900-7391	Divider, Cabinet
8	910-7377	Side, Left or Right Cabinet, 17SMS Stainless Steel

ITEM	PART #	COMPONENT
	900-7377	Cold Rolled Steel (Painted)
9	210-8305	Back, Cabinet, 17SMS
10	900-1750	Panel, Plumbing Access
11	900-4645	Shield, Heat
12	210-0007	Backsplash
13	210-0215	Plate, Faucet Mounting
14	810-1838	Rod, Basket Pivot
15	809-0200	Washer, ½-inch Flat
17	824-0801	Topcap, 17EC1CS, Fazoli's
*	824-0434	Topcap, 17E1, no rinse tank
18	806-5487	Frame, Control Panel
19	823-2946	Panel, Control
21	106-0590	Door Assembly, Left or Right (does not include handle or hinges)
22	810-1508	Hinge, Universal Door
23	210-0817	Shield, Left Moisture
24	210-0818	Shield, Right Moisture
25	910-4831	Bracket, Basket Lift Roller
27	810-0374	Spacer, Basket Lift Roller Tubular
28	810-0194	Roller, Basket Lift
29	809-0190	Washer, ¼-inch SS Flat
30	809-0047	Nut, ¼-20 Hex Head Cap
31	809-0127	Screw, ¼-20 x ½-inch Slotted Round Head
32	810-2229	Hanger, basket wire
33	809-0171PK	Thumbscrew, Basket Hanger (20)
34	230-4963	Handle, door

### Fasteners

ITEM	PART #	COMPONENT
*	826-1371	Screw, #8 x ½-inch Hex Head (access panel screw)
*	809-0740	Screw, #10 x ½-inch Phillips Truss Head (faucet plate and topcap screw)
16	809-0063	Nut, ⅜-16 Jam
20	826-1351	Retainer, ¼-20 Nut (Nutsert) (Pkg of 10)
*	809-0266	Screw, #10 x ½-inch Phillips Truss Head (door panel and handle screw)
26	809-0508	Bolt, ¼-20 x 1 ¼-inch Hex Head
29	809-0190	Washer, ¼-inch SS Flat
30	809-0047	Nut, ¼-20 Hex Head Cap
31	809-0127	Screw, ¼-20 x ½-inch Slotted Round Head

\* Not illustrated.

# 8SMS Cabinet Components

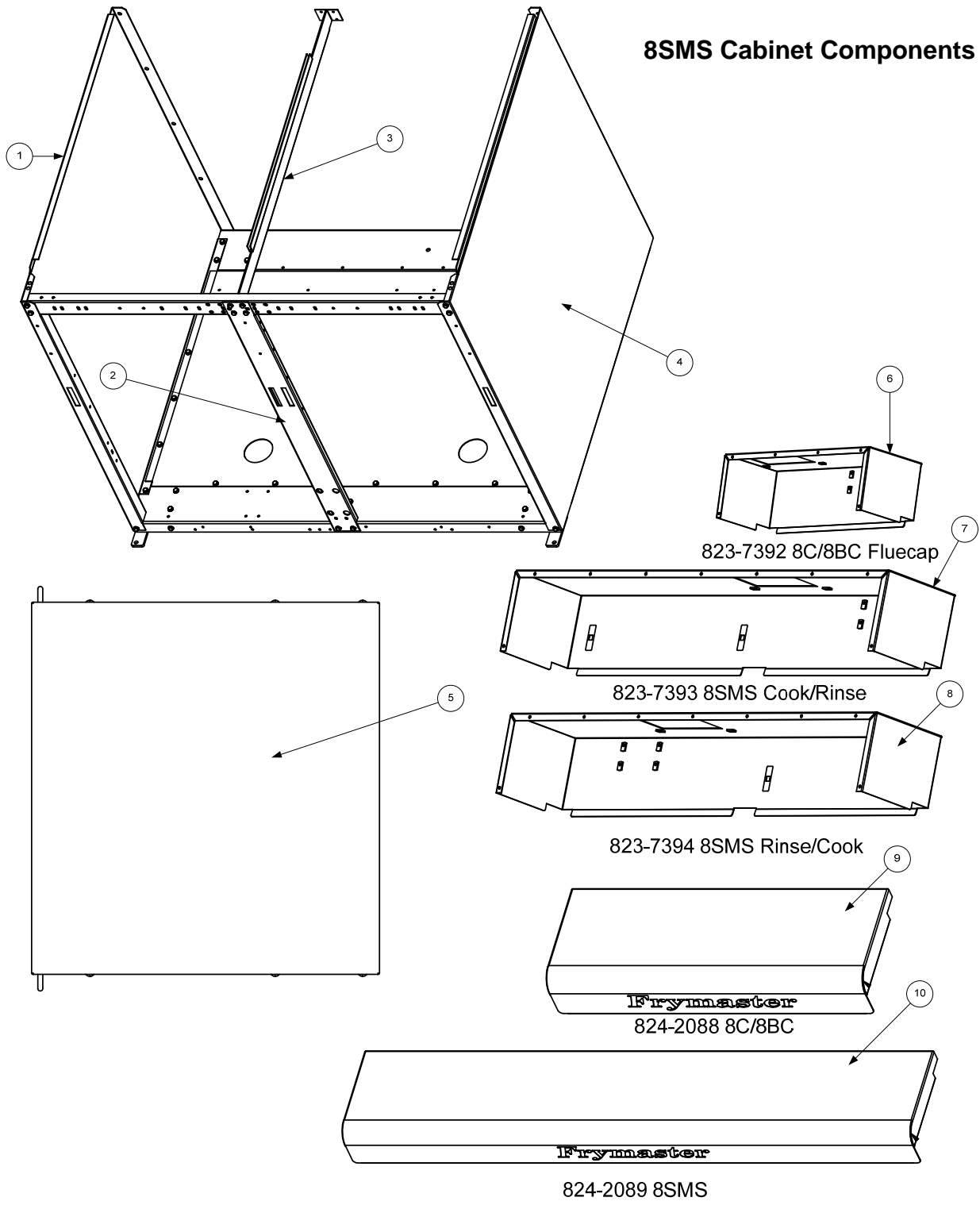

Item	Part #	Component
1	231-5452	Side, left, stainless
	221-5452	Side, left, cold rolled
2	220-5455	Door post
3	220-5826	Divider
4	232-5452	Side, right, stainless
	222-5452	Side, right, cold rolled
*	230-5733	Back
*	220-6246	Single cabinet back
5	108-0577	Door, SMS
*	106-4067	Door pin assembly
*	810-0275	Spring, door pin
*	220-5760	Door, liner
*	230-4963	Handle
*	810-1105??	Door, magnet
6	823-7392	8C/8BC flue cap
7	823-7394	8SMS Rinse/Cook flue cap
8	824-2088	8C/8BC top cap
9	824-2089	8SMS top cap

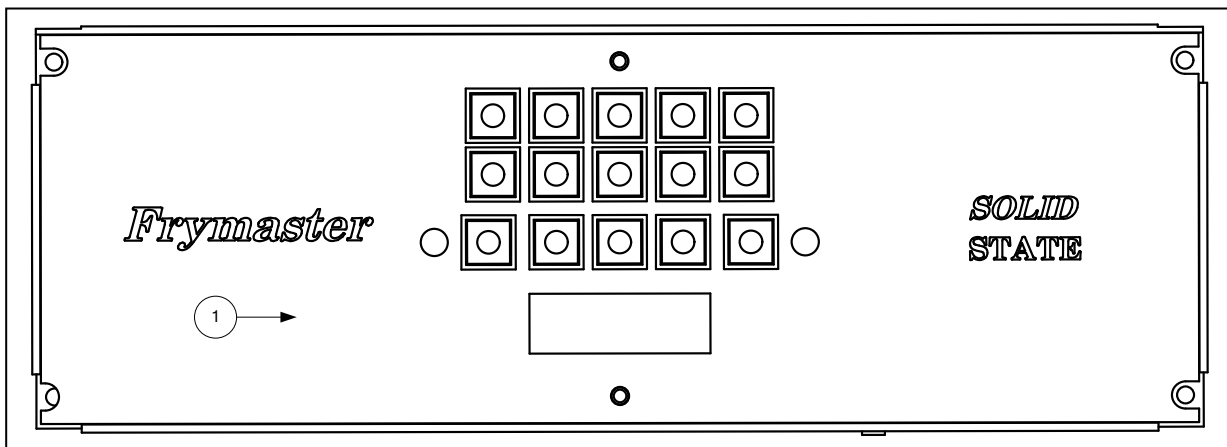

### Controllers

Item	Part #	Component
1	106-0384	Computer, 17SMS, Fazoli's
	106-0385	Computer, 17SMS
	106-2926	Computer, 17SMS, Noodles
	108-1131	Computer, 8SMS, with skim

**17 SMS COOKPOT, RINSE  
TANK, AND DRAIN  
COMPONENTS**

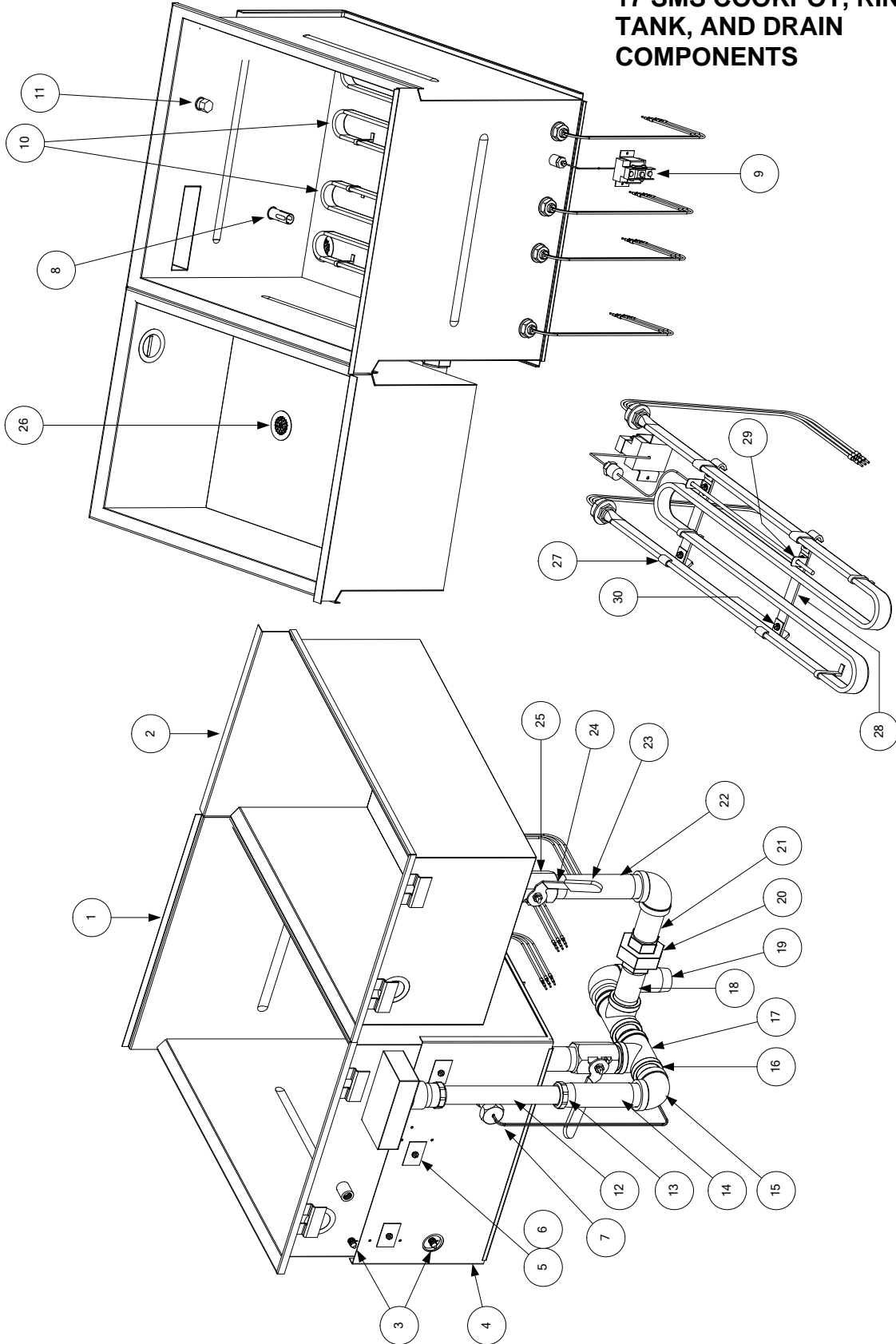

Detail of High-Limit Thermostat  
Mounting Hardware

ITEM	PART #	COMPONENT
1	106-0461	Cookpot Assembly (for 17EMCS (McDonald's), use 823-3827SP)
2	106-0543	Rinse Tank Assembly
3	806-7552SP	Water level sensor assembly
4	900-5045	Retainer, Cookpot Front Insulation
*	816-0152	Insulation, Cookpot Front (behind Item 4)
5	900-1762	Retainer, Insulation
6	826-1376	Nut, 10-32 Hex Head Keps (Pkg of 10)
7	807-3333	Probe, Temperature
8	210-0681	Guard, Temperature Probe
9	826-1601	Thermostat, High-Limit
10	807-3814	Element, 208V 8.625kW (for 230V, use 807-3815; for 240V, use 807-3816)
11	810-0976	Nozzle
12	813-0451	Nipple, 1 1/4-inch NPT x 12-inch Chromed Brass
13	813-0453	Nut, 1 1/4-inch NPT Chromed Stainless Steel Slip
14	813-0148	Nipple, 1 1/4-inch NPT x 6 1/4-inch NPT
15	813-0070	Elbow, 1 1/4-inch NPT 90°
16	813-0400	Nipple, 1 1/4-inch NPT x 2-inch
*	813-0391	Nipple, 1 1/4-inch NPT Close (connects cookpot drain valve and Item 19)
17	813-0394	Tee, 1 1/4-inch NPT
18	813-0146	Nipple, 1 1/4-inch NPT x 4 1/4-inch
19	813-0518	Nipple, 1 1/4-inch NPT x 4-inch
20	813-0395	Union, 1 1/4-inch NPT
21	813-0144	Nipple, 1 1/4-inch NPT x 3 3/4-inch
22	813-0554	Nipple, 1 1/4-inch NPT x 7-inch
23	814-0047	Sleeve, Red Drain Valve Handle
24	910-9527	Handle, Drain Valve
25	810-1825	Valve, 1 1/4-inch NPT Drain
26	823-2022	Strainer
27	910-2042	Clamp, Element
28	910-5214	Support, Element
29	910-2097	Bracket, High-Limit
30	809-0518	Screw, #8 X 3/8-inch S/S Hex Washer Slot Head
*	809-0204	Washer, Teflon (fits between Item 10 and inside face of Cookpot)
*	809-0063	Nut, 3/8-16 Jam (secures Drain Valve Handle to Drain Valve)

\* Not illustrated.

# 8 SMS COOKPOT, RINSE TANK, AND DRAIN COMPONENTS

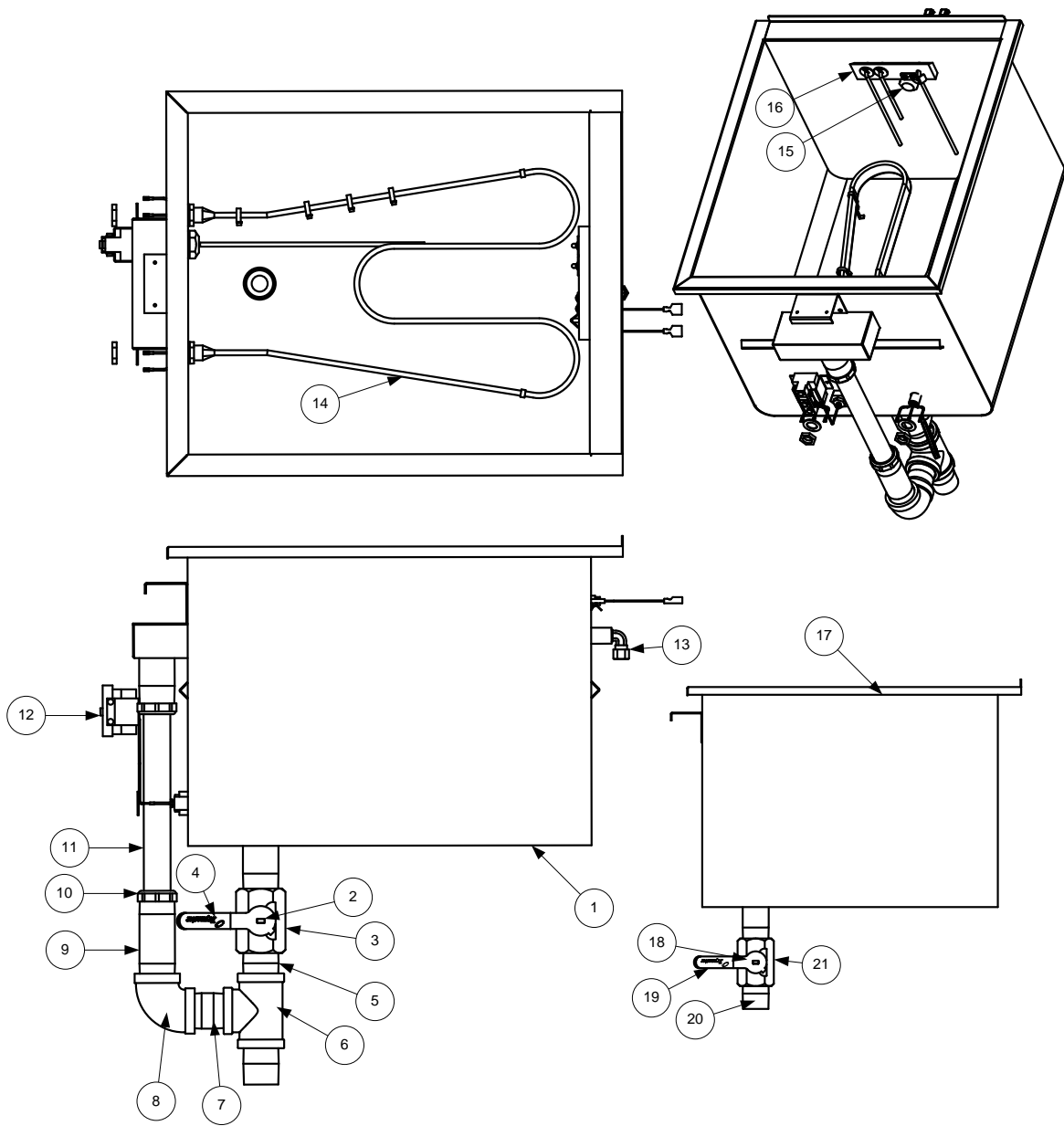

<b>ITEM</b>	<b>PART #</b>	<b>COMPONENT</b>
1	823-7044	Cookpot assembly
2	210-0151	Handle, s/s drain valve
3	810-1825	Valve, SS 1 1/4 x 1 1/4 drain
4	814-0047	Sleeve, handle vlv red
5	8130391	Nppl, 1 1/4NPT x close bm
6	813-0394	Tee, 1 1/4NPT bm
7	813-0451	Nppl, 1 1/4 x 12.00 chrome/brs
8	813-0070	Elbow, 1 1/4 NPT 90deg bm
9	8130-146	Nppl, 1 1/4npt x 4.25 bm
10	813-0453	Nut, slip 1 1/4NPS chrome stl
11	813-0451	Nppl, 1 1/4 x 12.00 chrome/brs
12	826-1601	Thermostat, high limit
13	813-0302	Elbow, mle 3/8tbe to 1/4npt brs
14	826-1798	Element, 240v 8000 watts 3p
15	810-0713	Nozzle, spray
16	806-9366	Block assy w/auto probe
17	823-7045	Rinse tank assembly
18	210-0151	Handle, s/s drain valve
19	814-0047	Sleeve, handle vlv red
20	813-0391	Nppl, 1 1/4NPT x close bm
21	810-1825	Valve, SS 1 1/4 x 1 1/4 drain

17 SMS ELECTRONICS

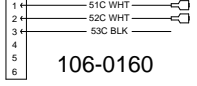
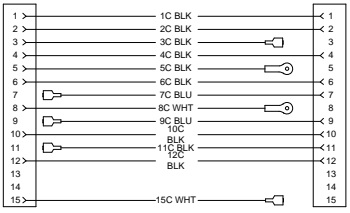
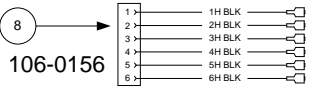
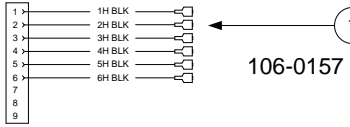
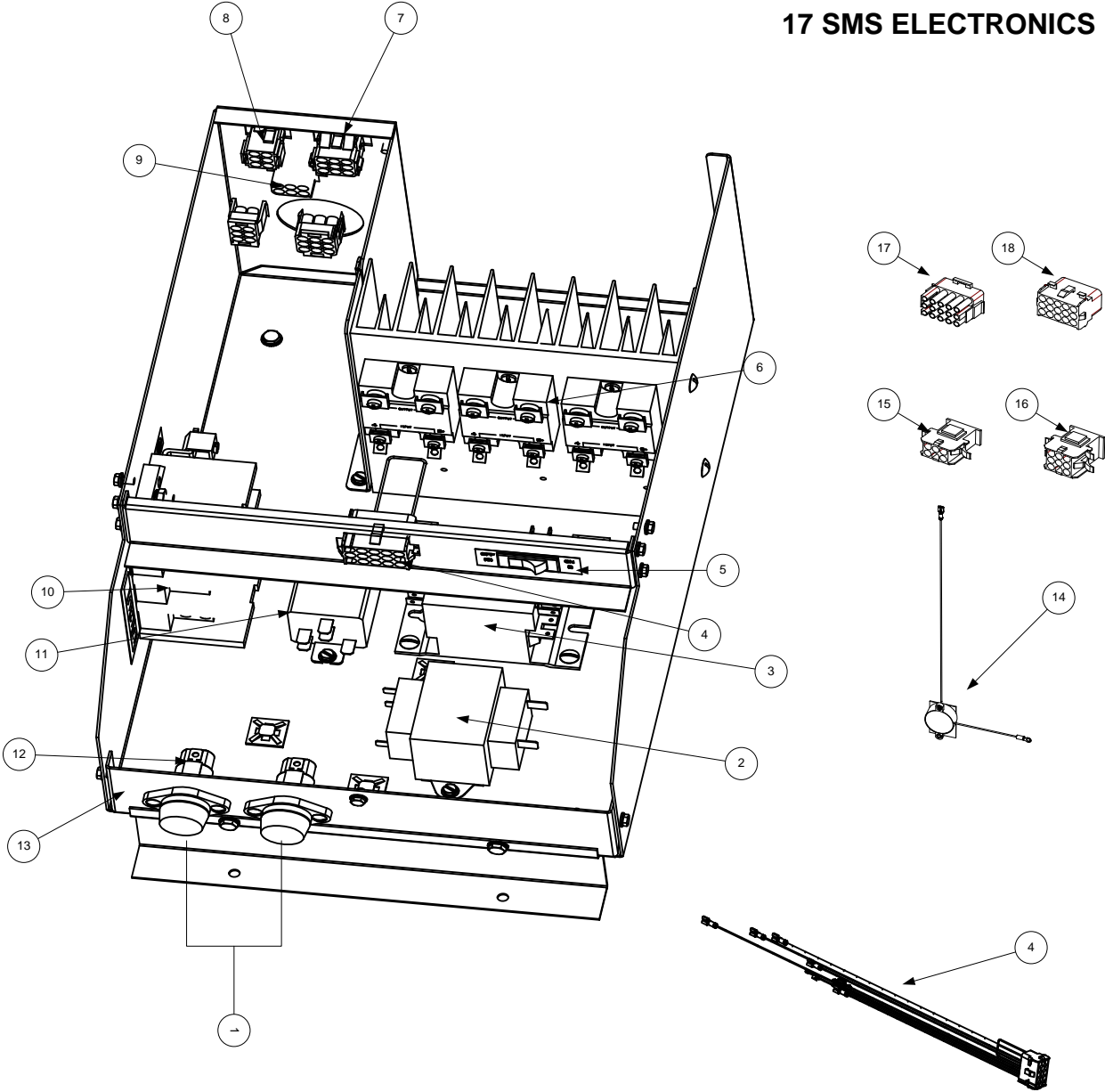

Computer harness

ITEM	PART #	COMPONENT
*	824-0856	<i>Starch Shield (mounts to back of control panel to protect computer)</i>
1	807-0922	Holder, fuse
2	807-0680	Transformer, 208-240VAC/24VAC 50/60Hz 43VA
3	810-1202	Contactator, 3 Pole 600VAC 40 Amp
4	106-7574	Harness, 15-pin control box
5	807-2082	Switch, Non-Illuminated Rocker
6	807-3996	Relay, 75 Amp 280V SPST-NO Solid State
7	106-0157	Harness, 9-pin harness, Fazoli's
8	106-0156	Harness, 6-pin
9	106-7573	Harness, 6-pin
10	807-2464	Power block, Delta
11	807-1396	Relay, 24V, SPDT
12	807-2279	Fuse, 15 amp
13	106-7575	Contactator box assembly
14	806-3660	Sound device
15	807-2136	Connector, 6-pin, female
16	807-2138	Connector, 9-pin, female
17	807-0804	Connector, 15-pin, male
18	807-0875	Connector, 15-pin, female
*	900-5445	Cover, front, contactor box
*	900-5895	Cover, top, contactor box
*	900-8239	Contactator box

\* Not illustrated.

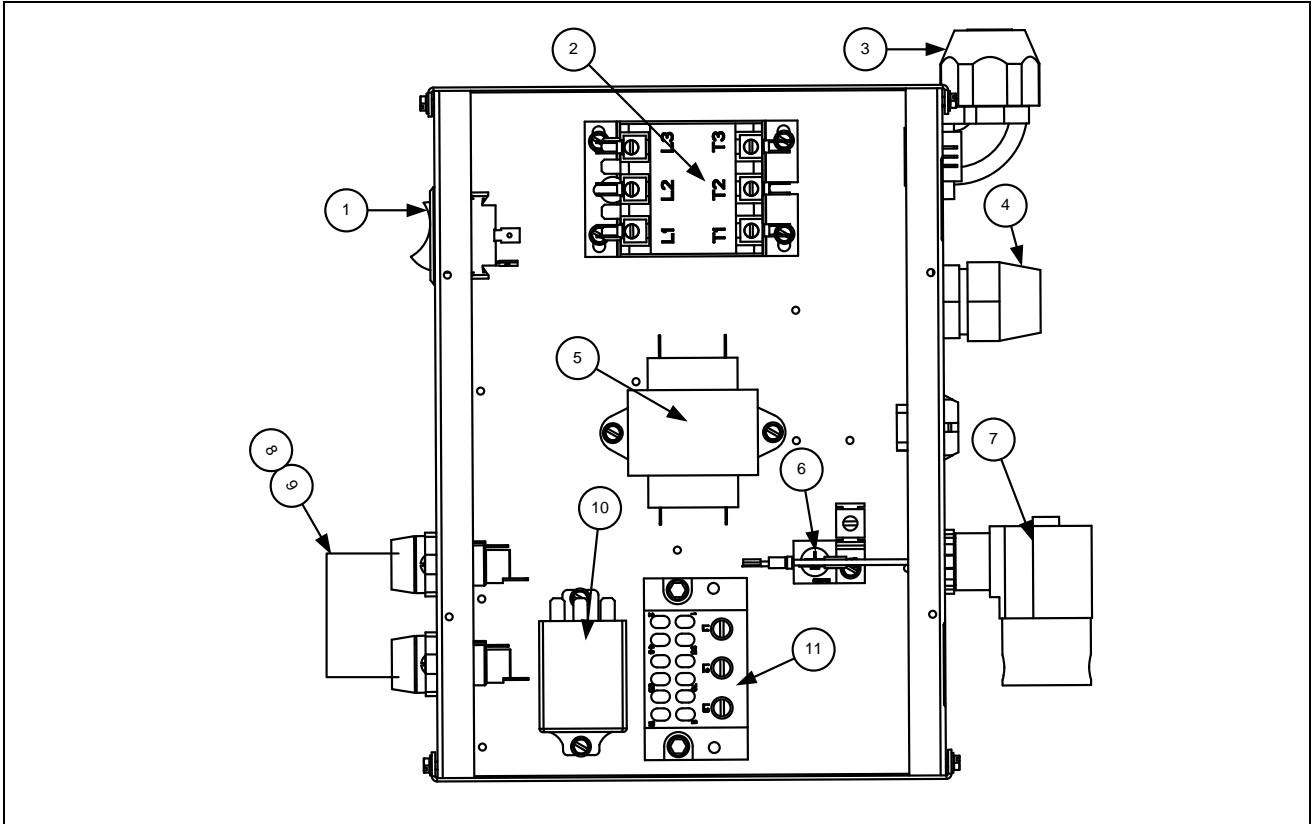

ITEM	PART #	COMPONENT
1	807-4036	Switch, dpst rckr
2	807-2284	Contactor,50 amp mech 24v coil
3	807-4483	Fitting,pastic conduit 3/4x90d
4	807-1292	Fitting,conduit plastic
5	807-0680	Transformer primary 208/240v
6	807-0070	Terminal ground lug
7	807-1393	Valve,solenoid 2 way 1/4npt
8	807-0922	Holder screw type Buss fuse
9	807-2279	Fuse, 15 amp
10	807-1396	Relay 24 dc spdt
11	220-4211	Bracket,strain relief sms
*	823-6293	Box, contactor 8sms
*	900-7853	Cover, contactor box

## Water supply system components

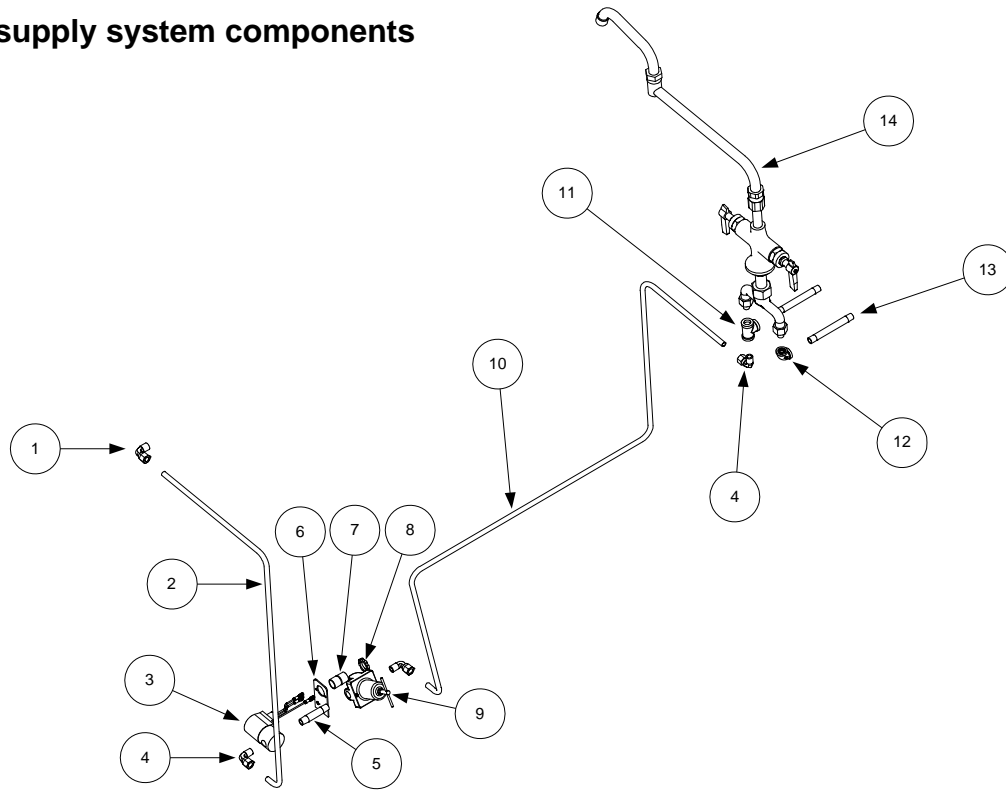

ITEM	PART #	COMPONENT
1	810-0907	Elbow, $\frac{3}{8}$ -inch NPT Compression
2	910-2513	Tubing, Solenoid Valve to Cookpot $\frac{3}{8}$ -inch Stainless Steel
3	806-5565	Valve Assembly, 24VAC 60Hz Solenoid
4	813-0302	Elbow, $\frac{3}{8}$ -inch Tube to $\frac{1}{4}$ -inch NPT 90° Brass Male
5	813-0472	Nipple, $\frac{1}{4}$ -inch NPT x 2.5-inch Brass
6	900-1905	Mount, Solenoid Valve
7	813-0022	Nipple, $\frac{1}{2}$ -inch NPT x Close
8	809-0454	Nut, $\frac{1}{2}$ -inch Conduit
9	810-1208	Valve, Pressure Regulator
10	900-1898	Tube, $\frac{3}{8}$ -inch Water Line
11	813-0449	Tee, $\frac{1}{4}$ -inch NPT Brass
12	813-0448	Elbow, $\frac{1}{4}$ -inch NPT 90° Brass
13	813-0473	Nipple, $\frac{1}{4}$ -inch NPT x 4-inch Brass
14	813-0412	Faucet, Double Jointed Pantry
*	826-1132	Kit, Faucet Repair (contains two valve assemblies)

\* Not illustrated.

## 2.2 Wiring Diagram 17E1

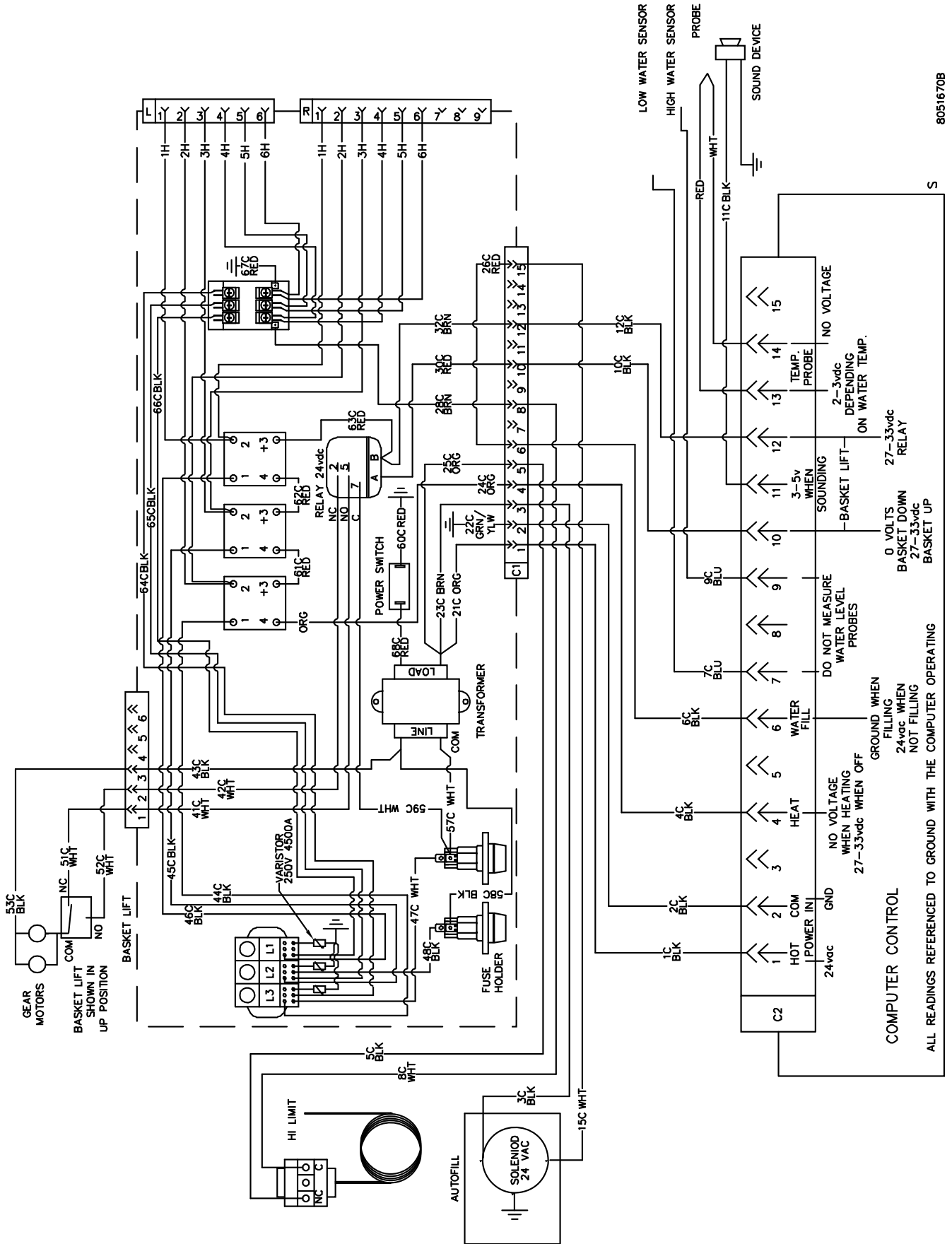

8051670B

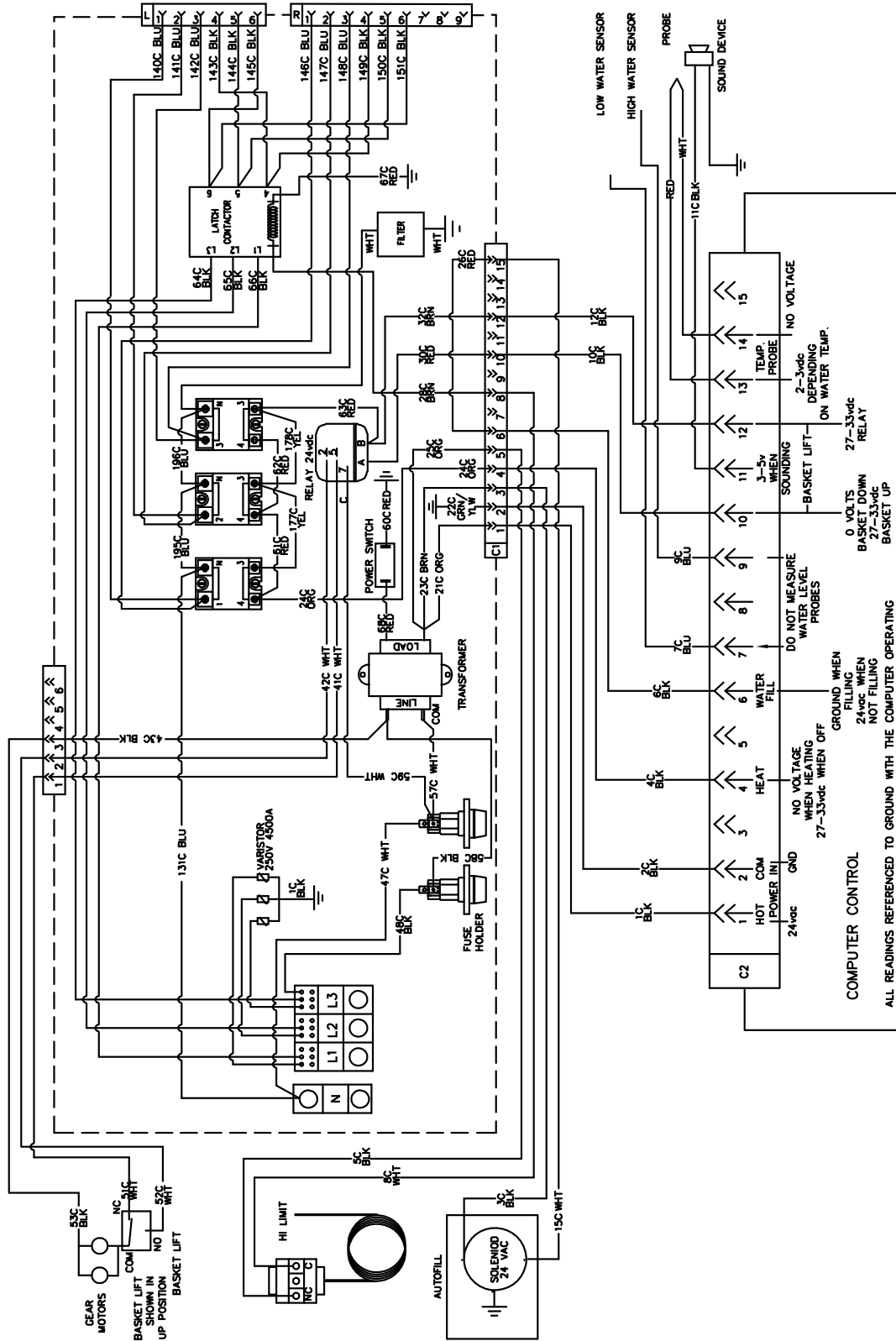

8051784A

## 2.4 Wiring Diagrams (8SMS)

208V 8KW ELEMENT			
VOLTS	PHASE	WATTS	AMPS/LINE
200	SINGLE	7400	37
200	3PH 3-WIRE	7400	22
200/347	3PH 4-WIRE	7400	13
208	SINGLE	8000	39
208	3PH 3-WIRE	8000	23

240V 8KW ELEMENT			
VOLTS	PHASE	WATTS	AMPS/LINE
240	SINGLE	8000	34
240	3PH 3-WIRE	8000	20
240/415	3PH 4-WIRE	8000	12

230V 8KW ELEMENT			
VOLTS	PHASE	WATTS	AMPS/LINE
220	SINGLE	7300	34
220	3PH 3-WIRE	7300	20
220/380	3PH 4-WIRE	7300	12
230	SINGLE	8000	35
230	3PH 3-WIRE	8000	21
230/400	3PH 4-WIRE	8000	12



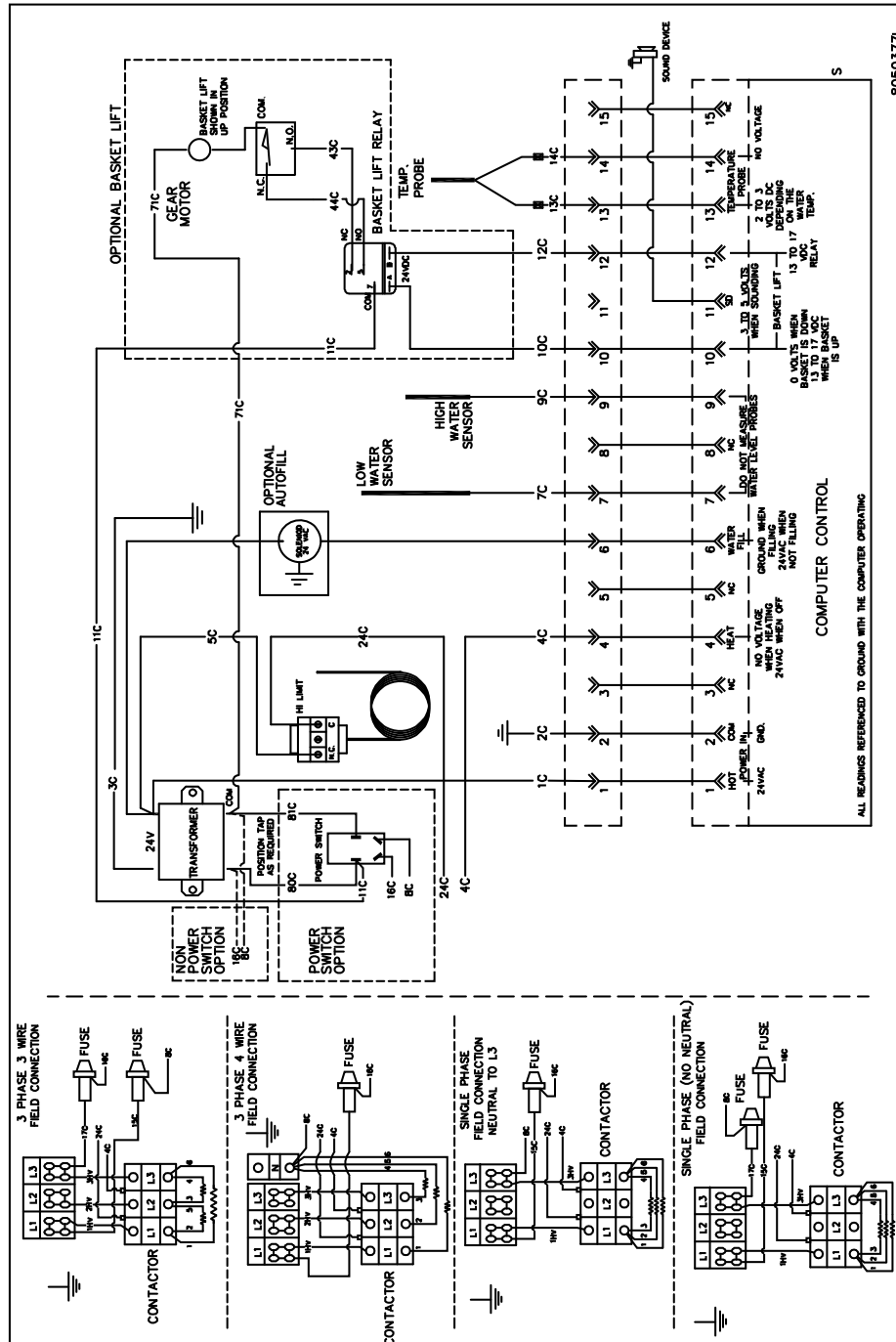

Shipping Address: 8700 Line Avenue, Shreveport, Louisiana 71106

TEL 1-318-865-1711 FAX (Parts) 1-318-219-7140 FAX (Tech Support) 1-318-219-7135

PRINTED IN THE UNITED STATES

SERVICE HOTLINE  
1-800-551-8633

819-6896A  
APR 2012